

SMXht Keypad/Display

Operates Both DX & TW AC Systems



SMXht Keypad/Display
with bronze Vimar bezel



Cruisair introduces SMXht, the latest in our line of SMXII series keypad/displays. The SMXht is a microprocessor-based controller designed for use with the SMX II-HV power/logic board. It is operable with both DX and TW systems and can be retrofitted to existing SMXII type systems in the field. The control is dual 115/230 voltage and operates at 50 or 60 cycles. Functionally, it is identical to our current SMXir keypad/display (sans remote), but is easier to program and operate.

The new SMXht is available in gray or white and has a sleek, modern European design. Two popular decorative snap-on bezels, Vimar® Idea or Gewiss® Playbus, are available for the keypad/display. The Gewiss bezel snaps directly onto the display; the Vimar bezel requires the use of two "wings" (included) to snap onto the display. (Bezel styles are limited, and are sold separately.) The keypad/display features raised buttons for easy access and control and an attractive, blue backlit LCD. The blue LCD has three levels of brightness or a programmable sleep mode in which the display is darkened automatically when not in use. With these new features, programming and operation is simple and easy. Installation is also uncomplicated; see the back of this sheet for a detailed diagram.

Normal operation consists of simply turning the system on by pressing the Power button and adjusting the desired cabin temperature setpoint. Fan speed is automatically controlled, (fan speed decreases as room temperature approaches setpoint), or the fan speed can be manually set. The modes available are: Cool, Heat, Auto Switchover (automatically switches from Cool to Heat Mode), or Dehumidification Mode. The dehumidification mode can be used to operate the system on a timed basis so that the boat will stay ventilated and dry even when no

Key Benefits

- Sleek modern Euro design
- Supports certain Vimar or Gewiss bezels
- Backlight and Sleep Modes
- Controls both DX and TW systems
- World First Technology
- Automatic Dehumidification
- Complete System Monitoring
- Supports Auxiliary Heat for TW systems
- Pressure Switch Testing
- Low Voltage Protection

one is aboard. Aux (electric) Heat Mode is available for TW systems.

SMXht offers the same outstanding a/c system protection as our other SMXII series controls. Line voltage and refrigerant high and low pressure switches are constantly monitored. If a problem is detected, the system will shut down and display a fault code on the keypad/display. A nonvolatile memory retains current operation mode and all programmable settings when power is turned off or lost, such as when

changing from generator to dock power. The programmable compressor time delay function will prevent multiple units from starting at the same time when power is restored.

Many of the factory settings can be changed to allow the user to fine-tune the system to best match the boat and personal preferences. (See the list of programmable functions.) A complete system consists of a power/logic module (the SMX II-HV), keypad/display, CXP connecting cable and a TSEP temperature sensor.

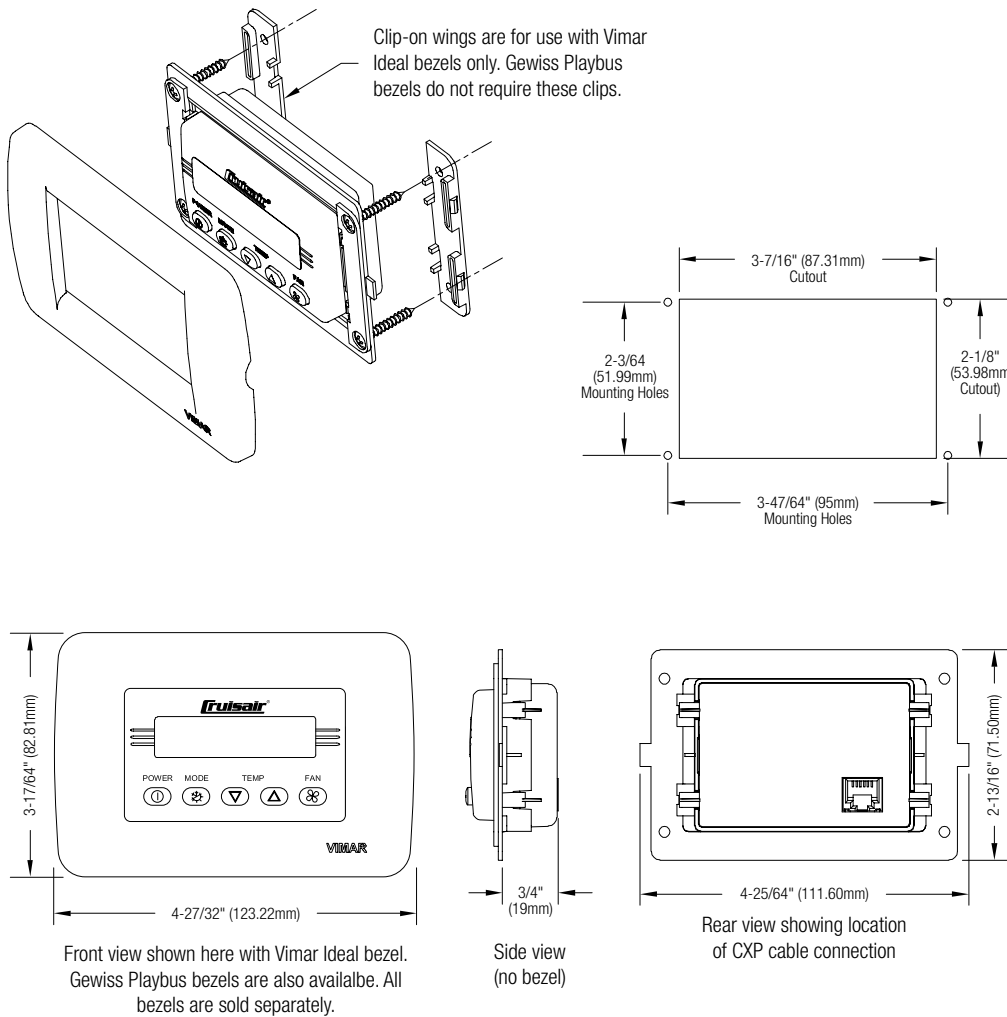

Programmable Functions

- Backlight Mode
- Select DX or TW power/logic board
- Fahrenheit/Celsius Display
- DX Compressor Time Delay
- Fan Response Differential
- Low and High Fan Speed
- AC Line Voltage Calibration
- Temperature Calibration
- HU Dehumidification
- High to Low Speed Adjustment
- Software Version
- Software Revision
- LED Segment Test
- Select SMXII power/logic board. (SMX Net will be supported in the future.)

DOMETIC CORPORATION, ENVIRONMENTAL DIVISION
 2000 N. Andrews Ave. Ext. | Pompano Beach, FL 33069 USA | 954-973-2477 | Fax 954-979-4414
 P.O. Box 15299 | Richmond, VA 23227 USA | 804-746-1313 | Fax 804-746-7248
 www.DometicEnviro.com | sales@DometicEnviro.com

United States & Canada Service Only:
 8:00 AM to 5:00 PM Eastern Time | Marine Air AC Products: 954-973-2477
 Cruisair AC Products: 804-746-1313

24/7 AC SERVICE HOTLINE: 5:00PM to 8:00 AM: 888-440-4494

International Sales & Service:
 Europe & the Middle East: Call +44(0)870-330-6101
 For all other areas visit our website to find your nearest distributor.

Dealer:

