

SMX Series Control Systems

Microprocessor Systems for DX

Photo courtesy of Cruisers Yachts



SMXir Keypad/Display
with Remote Control

Cruisair offers two different SMX microprocessor control systems for use with direct expansion (DX) air conditioning systems. SMX

II offers all the standard operational and safety features required for most DX systems, SMX Net adds networking capability and other special features that make it unique in the industry. The SMX II or SMX Net power/logic board comes installed on the designated self-contained unit or condensing unit, or either system can be retrofitted in the field to replace an electromechanical switch assembly. The SMXir keypad/display and optional SMXir remote is used on both SMX II and SMX Net systems.

Normal operation consists of simply turning the system on by pressing either the Cool or Heat buttons and adjusting the desired cabin temperature setpoint. Fan speed is automatically controlled (fan speed decreases as room temperature approaches setpoint), or the fan speed can be manually set.

The dehumidification mode can be used to operate the system on a timed basis so that the boat will stay ventilated and dry even when no one is aboard.

Line voltage and refrigerant high and low pressure switches are constantly monitored and if a problem is detected, the system will shut down and display a fault on the keypad/display.

Many of the factory settings can be changed to allow the user to fine-tune the system to best match the boat and personal preferences. (See the chart on the back for a list of programmable functions.)



Key Benefits

- Works with SMXII or SMX Net Control Systems
- Optional Remote Control
- Automatic/Manual Fan Speed Control
- Optional 2-Speed Fan (SMX Net only)
- Inside Temperature Display
- Outside Temperature Display (SMX Net only)
- Dehumidification (absent) Program
- Nonvolatile Memory
- Low Voltage Shutdown
- High Pressure Shutdown
- Low Pressure Shutdown
- Fault Display
- Software Update Capability (SMX Net only)
- Remote System Control (SMX Net only)
- Slaving Capability (SMX Net only)
- Optional Convenience Panel (SMX Net only)
- Auxiliary Heat Control (SMX Net only)
- Brightness Control

A nonvolatile memory retains current operation mode and all programmable settings when power is turned off or lost, such as when changing from generator to dock power. The programmable compressor time delay function will prevent multiple units from starting at the same time when power is restored.

In addition to all of the standard SMX functions listed above, the SMX Net system allows multiple units to be networked together for central control. Each unit in the network has a unique ID number, and any unit can be accessed and controlled from any other control in the network. SMX Net also permits one unit to be "slaved" to another so that only one keypad can be used to control multiple units in a large cabin. Additional SMX Net features include outside temperature display, auxiliary (electric) heat control, 2-speed fan control, and an optional SMX Net Convenience Panel, from which the entire network can be easily accessed and controlled with a single keystroke to go into one of four programmed modes.

The **SMXir** keypad/display has an attractive, compact housing with easy surface-mount installation. A large, easy-

to-read LED display shows cabin temperature, setpoint, programming prompts, and fault code warnings, and small LEDs and backlit text indicate system status. Under a decorative hinged door is the familiar SMX 10-button arrangement with clearly labeled keys for single-keystroke operation. An optional infrared remote control is available that allows system adjustments to be made remotely.

The SMXir keypad/display can be used with either SMX II or SMX Net control systems. A complete system consists of a power/logic module (either SMX II or SMX Net), an SMXir keypad/display, CXP connecting cable and a TSEP temperature sensor. Additional components will be needed to network multiple SMX Net units, including: CNP network cables, one TSEP outside temperature sensor, and the optional SMXir Convenience Panel (the convenience panel kit includes a SMXir keypad/display connected to a SMXir Convenience Panel).

Specifically designed for the marine environment, the SMXir features a plastic housing, sealed membrane keypad, and electronics with anticorrosion coating. Housings are available in black or white, and with either a 3/4 or full coverage door.

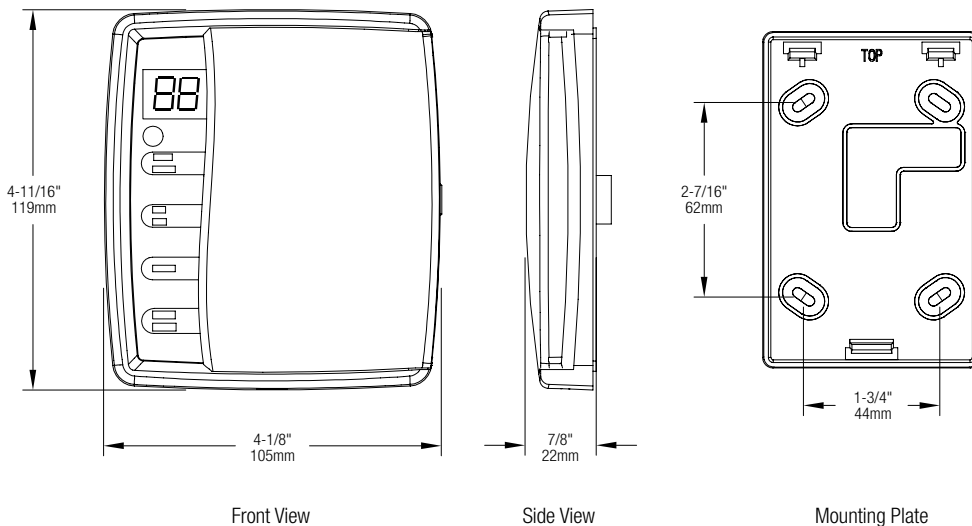

Programmable Functions

- Fahrenheit/Celsius Display
- Low Fan Speed Adjustment
- High Fan Speed Adjustment
- Compressor Time Delay
- Compressor Response Differential
- Fan Response Differential
- Continuous/Intermittent Fan
- Line Voltage Calibration
- Temperature Sensing Calibration
- Factory Memory Reset
- Dehumidification Cycle Parameters

DOMETIC CORPORATION, ENVIRONMENTAL DIVISION
 2000 N. Andrews Ave. Ext. | Pompano Beach, FL 33069 USA | 954-973-2477 | Fax 954-979-4414
 P.O. Box 15299 | Richmond, VA 23227 USA | 804-746-1313 | Fax 804-746-7248
 www.DometicEnviro.com | sales@DometicEnviro.com

United States & Canada Service Only:
 8:00 AM to 5:00 PM Eastern Time | Marine Air AC Products: 954-973-2477
 Cruisair AC Products: 804-746-1313

24/7 AC SERVICE HOTLINE: 5:00PM to 8:00 AM: 888-440-4494

International Sales & Service:
 Europe & the Middle East: Call +44(0)870-330-6101
 For all other areas visit our website to find your nearest distributor.

Dealer:

