

# Dometic EnviroComfort Retrofit Kits (R-410A)

## Climate Control At the Touch Of a Button



Enjoy ideal temperatures on your boat year-round with EnviroComfort (ECD) self-contained air conditioning kits, now available with R-410A refrigerant, an environmentally safe gas.

ECD R-410A kits are available in 6,000, 10,000, and 16,000 BTU/hr cooling and reverse-cycle heating capacities, so you can size the system to suit your boat for ultimate comfort in a range of climates.

All units have high-velocity blowers with internal motors for a more compact installation footprint. The blower can be rotated to a horizontal or vertical position for greater installation flexibility. Units are built on an easy-to-plumb stainless-steel drain pan, and the pre-installed return-air filter is removable for cleaning.

ECD units are operated by a compact digital control/display (included) that features a bright green LED and large buttons. For added installation convenience, the plastic electrical box can be mounted remotely.

ECD kits are ideal for replacing an existing air conditioning system or for a new air conditioning installation. The Retrofit Kit includes the ECD self-contained air conditioning unit and digital control with bezel and is intended to replace an older self-contained air conditioner of comparable capacity. The ECD6K will replace a 5,000 to 7,000 BTU/hr unit; the ECD10K will replace an 8,000 to 11,000 BTU/hr unit; and the ECD16K will replace a 12,000 to 16,000 BTU/hr unit.

The Installation Kit includes all air distribution and plumbing components that, when combined with the Retrofit Kit, comprises an entirely new air conditioning system installation that is suited for treating one interior space. If air conditioning a second interior space is desired, add the Dual Duct Kit which includes a "Y" duct ring connector, 12.5 ft. (3.8 m) of flexible insulated duct, and a circular supply air grille.



The ECD Installation Kit includes all air distribution and plumbing components that, when combined with the ECD Retrofit Kit, comprise a complete air conditioning system installation.



The optional Dual Duct Kit will air condition an additional interior space.

### Key Benefits

- High velocity, rotatable blower for horizontal or vertical installation
- Environmentally safe R-410A refrigerant
- Compact Dometic digital display/control
- Plastic remote electrical box for convenience in mounting
- Stainless-steel drain pan
- Pre-installed return-air filter, easily removable and cleanable
- Small, compact, space-saving design
- Retrofit Kit includes digital control and replaces an existing self-contained air conditioning unit
- Optional Dual Duct Kit for air conditioning an additional interior space
- Available in 6,000, 10,000, and 16,000 BTU/hr capacities

# Specifications for Dometic EnviroComfort Retrofit Kits (R-410A)

Model	EC6K-410A	EC10K-410A	EC16K-410A
Part Number (P/N)	207500306	207500310	207500316
Capacity (BTU/h)	6000	10000	16000
Voltage (V)	115	115	115
Cycle (Hz)/Phase (Ph)	60/1	60/1	60/1
Full Load Amps (FLA) Cool (A)	4.6	7	10.5
Full Load Amps (FLA) Heat (A)	5.9	9.1	13.7
Locked Rotor Amps (LRA) (A)	36	42	62
Max. Circuit Breaker (A)	15	25	40
Min. Circuit Ampacity (A)	12	16	25
Refrigerant Type	410A	410A	410A
Height (in/mm) <sup>(1)</sup>	11.25/286	13.25/337	13.5/343
Width (in/mm) <sup>(1)</sup>	16/407	20/508	20/508
Depth (in/mm) <sup>(2)</sup>	9/229	9.63/245	11.25/286
Min. Supply Duct Size (in/mm)	4/102	6/153	6/153
Seawater Inlet Connection (in/mm)	3/8	1/2	1/2
Net Weight <sup>(3)</sup>	38 lbs/17.3 kg	57 lbs/25.9 kg	64 lbs/29.1 kg
Height-Electrical Box (in/mm)	8.75/223	8.75/223	8.75/223
Width-Electrical Box (in/mm)	6.5/166	6.5/166	6.5/166
Depth-Electrical Box (in/mm)	2.7/71	2.7/71	2.7/71

<sup>1</sup> All dimensions ± 0.30 in. (8 mm).

## Dimensions

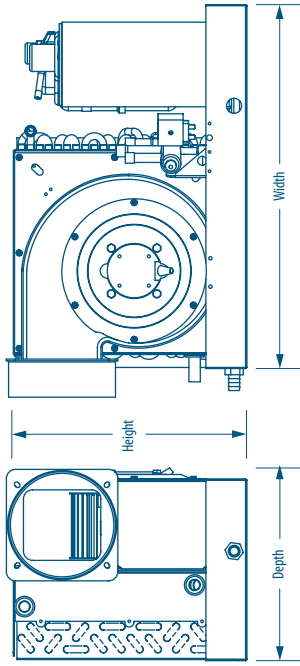

## Installation

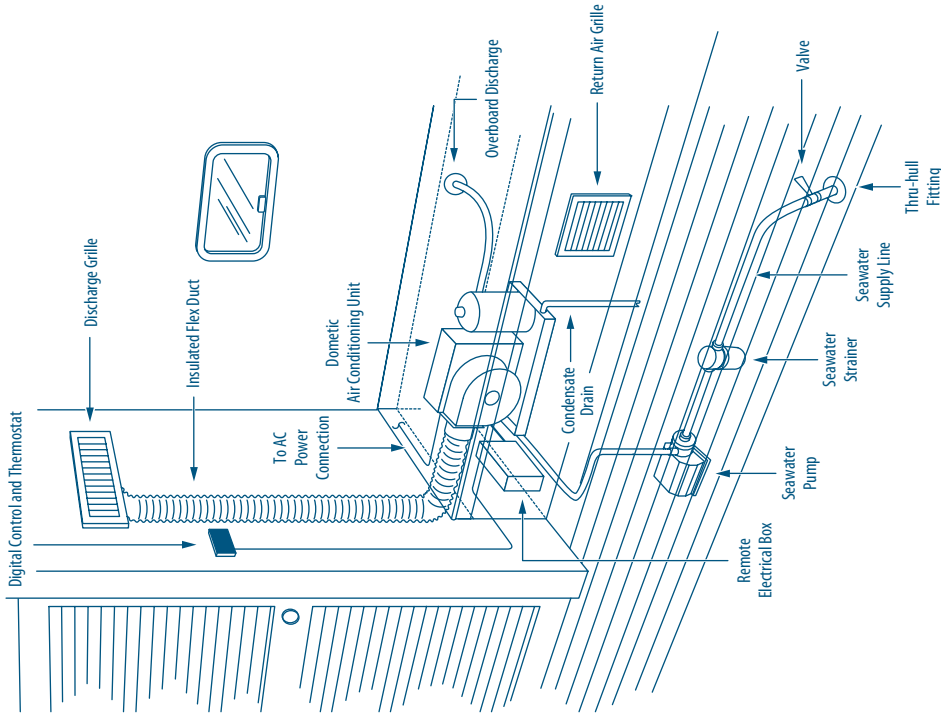

Dealer



**DOMETIC MARINE DIVISION**  
 2000 N. Andrews Ave. Ex. | Pompano Beach, FL 33069 USA | Tel. 954-973-2477 | Fax: 954-979-4414  
 www.Dometic.com/Marine | MarineSales@DometicUSA.com

**24/7 TECH SUPPORT FOR UNITED STATES & CANADA:**  
 8:00 AM to 5:00 PM Eastern Time: 800-542-2477  
 After hours and weekends: 888-440-4494

**INTERNATIONAL SALES & SERVICES**  
 Europe & the Middle East: Call +44(0)870-330-6101  
 For all other areas visit our website to find your nearest distributor.

L-3003 Rev. 20131025

Specifications and availability subject to change without notice.