

MASTERVOLT

INSTALLATION AND COMMISSIONING OF MULTIPLE BATTERIES

Li-ion Battery

MLi Ultra 12/2500

MLi Ultra 12/5000

MLi Ultra 24/5000



MASTERVOLT
Snijdersbergweg 93
1105 AN Amsterdam
The Netherlands
Tel.: +31-20-3422100
Fax.: +31-20-6971006
www.mastervolt.com

ENGLISH:	PAGE 1
NEDERLANDS:	PAGINA 17
DEUTSCH:	SEITE 33
FRANÇAIS:	PAGINA 49
CASTELLANO:	PAGINA 65
ITALIANO:	PAGINA 81

Copyright © 2013 Mastervolt. All rights reserved. Reproduction, transfer, distribution or storage of part or all of the contents in this document in any form without the prior written permission of Mastervolt is prohibited.

TABLE OF CONTENTS:

10000005933/02 August 2013

1	IMPORTANT INFORMATION	3
1.1	Unpacking	3
1.2	Needed for installation:.....	3
1.2.1	Ventilation.....	3
1.3	External cut-off relay	3
1.4	General installation guidelines.....	3
1.5	Connection module	4
2	INSTALLATION AND COMMISSIONING	5
2.1	Minimum safety requirements, multiple battery installation	5
2.2	Installation and commissioning.....	5
2.3	Charger settings	5
3	MULTIPLE BATTERY SYSTEM EXAMPLES	6
3.1	Parallel connection, total maximum SYSTEM current < 500 amps	6
3.1.1	Schematic installation (parallel connection, total maximum current < 500 Amps)	6
3.1.2	Required materials (parallel connection, total maximum current < 500 Amps).....	6
3.1.3	MasterBus configuration (parallel connection, total maximum current < 500 Amps)	7
3.1.4	Commissioning (parallel connection, total maximum current < 500 Amps)	7
3.2	Parallel connection, total maximum current > 500 a, max 500 a per battery	8
3.2.1	Schematic installation (parallel connection, total maximum current > 500 Amps)	8
3.2.2	Required materials (parallel connection, total maximum current > 500 Amps).....	8
3.2.3	MasterBus configuration (parallel connection, total maximum current > 500 Amps)	9
3.2.4	Commissioning (parallel connection, total maximum current > 500 Amps)	9
3.3	Serial connection 48V, using one charger for two batteries	10
3.3.1	Schematic installation (Serial connection 48V, one charger for two batteries)	10
3.3.2	Required materials (Serial connection 48V, one charger for two batteries).....	10
3.3.3	MasterBus configuration (Serial connection 48V, one charger for two batteries)	11
3.3.4	Commissioning (Serial connection 48V, one charger for two batteries)	11
3.4	Serial connection maximum 10 batteries.....	12
3.4.1	Schematic installation (Serial connection, maximum 10 batteries).....	12
3.4.2	Required materials (Serial connection, maximum 10 batteries)	12
3.4.3	MasterBus configuration (Serial connection, maximum 10 batteries).....	13
3.4.4	Commissioning (Serial connection, maximum 10 batteries).....	13
4	ORDERING INFORMATION	14
5	TECHNICAL INFORMATION MULTIPLE BATTERIES	15
5.1	Specifications	15

1 IMPORTANT INFORMATION



During installation and commissioning of the Li-ion batteries, the Safety Guidelines & Measures are applicable at all times. See chapter 1 of the single battery manual. For more info like operation, single battery schemes and installation environment, refer to the other chapters of the user's manual.

1.1 UNPACKING

After unpacking, check the contents for possible damage. Do not use the product if it is damaged. If in doubt, contact your supplier.

1.2 NEEDED FOR INSTALLATION:

- Hexagon socket wrench 13mm (M8 screw) to connect the battery cables to the Li-ion battery (torque: see single battery manual section 6.6)
- Tools to install the wiring
- 2 mm flat blade screwdriver to fasten the relay wiring
- 4 mm flat blade screwdriver to fasten the balance line wiring
- For adjustment of setpoints: A MasterBus control panel or laptop with configuration software and MasterBus - USB interface.

1.2.1 Ventilation

Place the battery in a sufficiently ventilated room.

1.3 EXTERNAL CUT-OFF RELAY



For safety purposes installation of a safety relay controlled by the battery is obligatory! Installation and commissioning of the Li-ion battery requires programming of events in a MasterBus communication network to control the battery charger. The installer must be familiar with the programming of such events. For nominal voltages above 48V an alternative relay must be used.

1.4 GENERAL INSTALLATION GUIDELINES

Refer to the single battery manual.

1.5 CONNECTION MODULE

The connection module consists of three parts, refer to figure 1-1:

- Relay Controls (1-6)
- MasterBus (7)
- Balance line for two batteries (8,9)

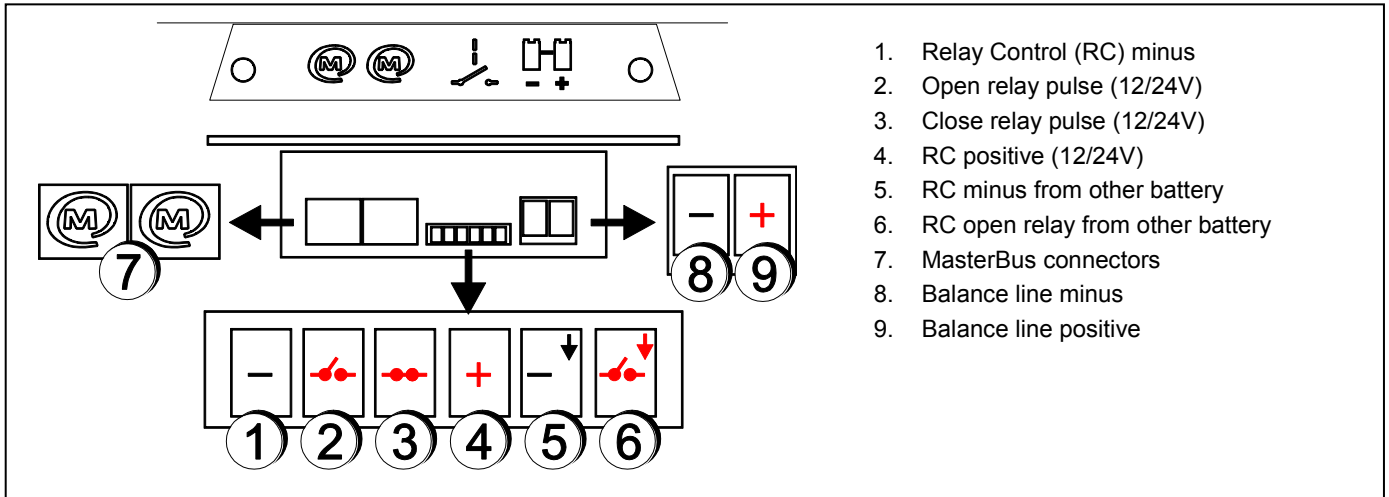

Figure 1-1: Connection module

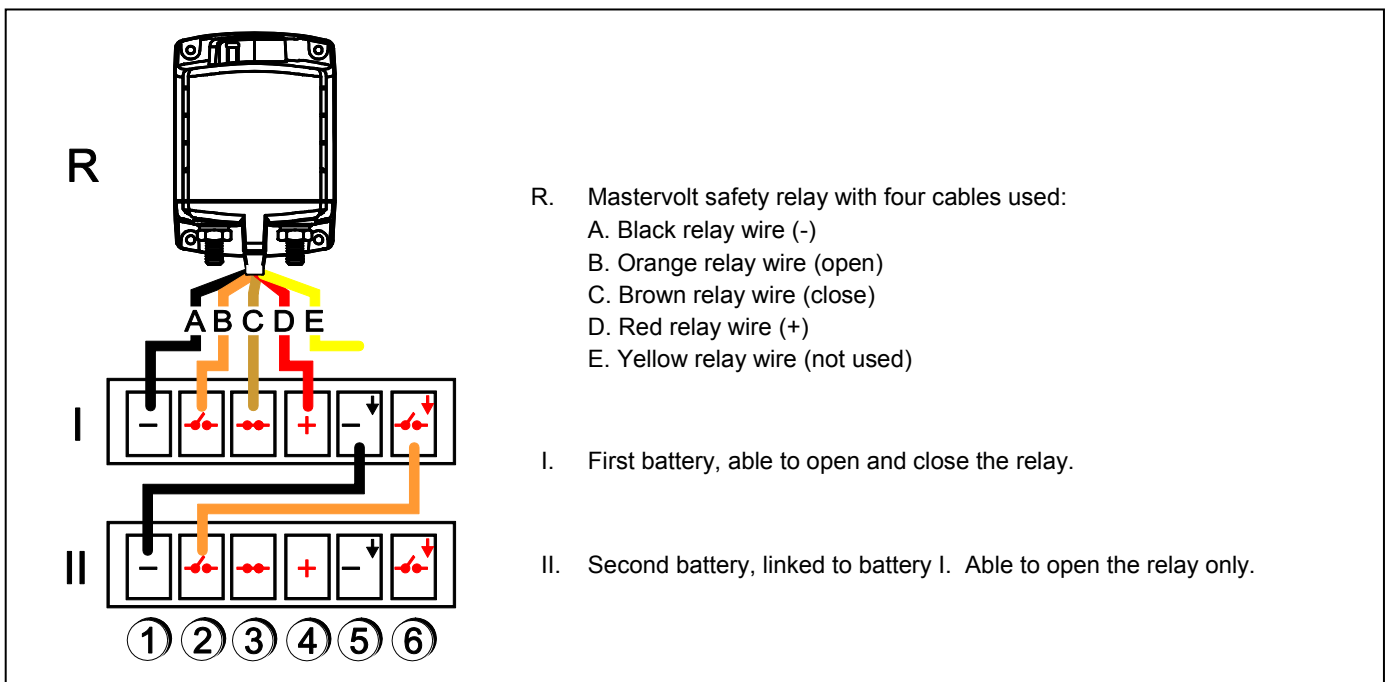

Figure 1-2: Shared relay for multiple batteries (max 2 in series)

See figure 1-2. Terminals 1 to 4 of the first battery (I) are connected to the relay, terminals 1 and 2 of the second battery (II) are connected to 5 and 6 of the first battery (I).

This way the two batteries can be protected by one relay, battery II leaving the option to open the relay only. Battery I can open and close the relay.

2 INSTALLATION AND COMMISSIONING

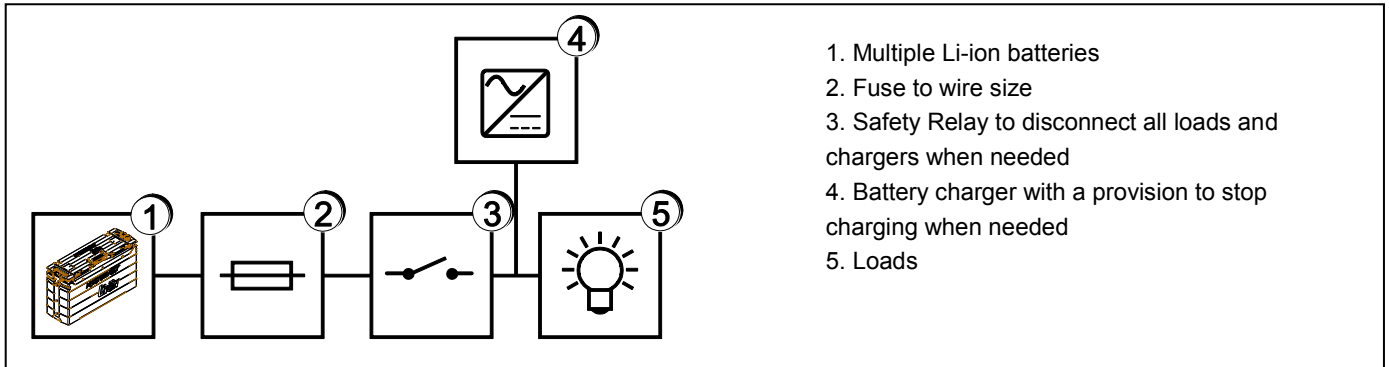

Figure 2-1: Battery system overview

1. Multiple Li-ion batteries
2. Fuse to wire size
3. Safety Relay to disconnect all loads and chargers when needed
4. Battery charger with a provision to stop charging when needed
5. Loads

Before the Li-ion battery can be used, it must be installed and commissioned.



CAUTION! The Li-ion battery is a special battery and it needs special safety precautions in the installation!

2.1 MINIMUM SAFETY REQUIREMENTS, MULTIPLE BATTERY INSTALLATION

To prevent hazardous situations YOU MUST:

- A. Install a safety relay to disconnect the battery under abnormal circumstances
- B. Install a charger that stops charging if the battery indicates so
- C. Use properly sized fuses and wiring
- D. Use cables of same length for batteries in parallel
- E. Configure the MasterBus Stop charge event

The graph in figure 2-1 shows a simplified overview of a safe Li-ion battery system.

1. Multiple MLI Ultra 12/2500, MLI Ultra 12/5000 or MLI Ultra 24/5000 batteries.
2. Fuse in the positive battery cables to protect DC cabling and batteries. It must correspond with the cable diameters up to maximum 500A. The IR must be at least 15000A.
3. Safety Relay(s), must be able to disconnect the loads and the charging devices when the battery enters an unsafe situation.
4. Battery charging device, must be able to stop charging or switch to the Float stage at a MasterBus event when the battery detects a “stop charge” condition. It has to be configured to charge a Li-ion battery, refer to charger settings in the MasterBus configuration.
5. DC loads.

If the charger is stopped, battery power is still available for the loads (5). If the safety relay (3) disconnects, there is no battery power available for the loads. Refer to single battery manual chapter 8 for advanced functionality,

explanation of the Battery Safety event and the Stop charge event.

2.2 INSTALLATION AND COMMISSIONING

Installation and commissioning depend on the system in which the Li-ion battery is used.



CAUTION!

With MasterBus Power enabled, the MasterBus network will drain the Li-ion Battery slowly, even if the battery has been disconnected from the system. Refer to the MasterBus configuration in the single battery manual.

We describe four multiple Li-ion battery systems:

- 1 two or more batteries in parallel, total maximum current < 500 Amps, section 3.1
- 2 two or more batteries in parallel, total maximum current > 500 Amps, section 3.2
- 3 two batteries in series, using one charger, section 3.3
- 4 up to 10 batteries in series, using a charger per battery, section 3.4

Select one of these options and continue with the corresponding section for installation and commissioning.

2.3 CHARGER SETTINGS

A single Mastervolt Li-ion battery can be charged with any standard Mastervolt battery charger. Adjust charge characteristic of the IUoUo characteristic as follows:

Nominal battery voltage	Bulk / absorption voltage setting	Float voltage setting
12V	14.6 V	13.5 V
24V	29.2 V	27.0 V

For higher voltages an alternative charger is necessary. Refer to the user’s manual of the battery charger for Li-ion charge settings.

3 MULTIPLE BATTERY SYSTEM EXAMPLES

3.1 PARALLEL CONNECTION, TOTAL MAXIMUM SYSTEM CURRENT < 500 AMPS

3.1.1 Schematic installation (parallel connection, total maximum current < 500 Amps)

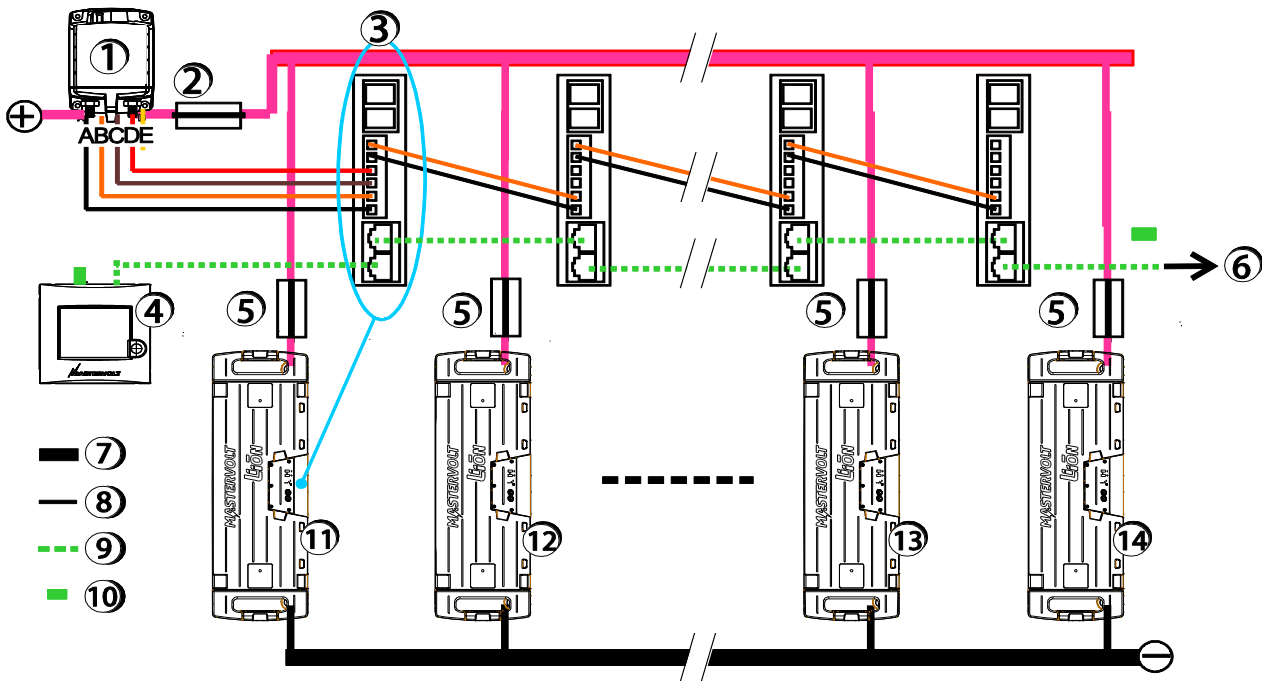

Figure 3-1: Parallel connection, current under 500A

- | | | |
|---------------------------------|------------------------------------|---------------------------|
| 1. Safety relay | 5. Battery fuse in positive line | 9. MasterBus cable |
| 2. Main fuse in positive busbar | 6. MasterBus connection to charger | 10. MasterBus terminator |
| 3. Connection module | 7. Busbar | 11-14. MLi Ultra battery |
| 4. MasterBus display | 8. Relay cable | A-E. Refer to figure 1-2. |

Follow next steps to install the safety relay:

- 1 Move the safety relay in the LOCK OFF position. See single battery manual section 4.8.
- 2 Connect the DC main wiring as indicated but do not place the Main fuse yet.
- 3 Connect the wiring for the control circuit of the safety relay as indicated.
- 4 Connect the MasterBus cabling between the devices as indicated. Keep the rules in mind as described in single battery manual section 5.2.
- 5 Add a MasterBus control panel to the MasterBus network.

3.1.2 Required materials (parallel connection, total maximum current < 500 Amps)

Quantity		Mastervolt	Description
@ 12V	@ 24V	Part number	
n	--	66012500	Li-ion Battery MLi Ultra 12/2500
n	--	66015000	Li-ion Battery MLi Ultra 12/5000
--	n	66025000	Li-ion Battery MLi Ultra 24/5000
1	--	79007700	Safety relay 12V/500A, part # 7700
--	1	79007702	Safety relay 24V/500A, part # 7702
1	1	77049000	500A Fuse to protect the DC Main Wiring*
1	1	778T2S600	T-Fuse holder for 77049000
1	1		MasterBus control panel (see single battery manual section 6.2)
**	**		DC Main Wiring, with Main Fuse depending on system current
**	**		Wiring for the safety relay control circuit, minimum cross section: 0.5mm ²
**	**		MasterBus communication cables

n number of MLi batteries

*Any other fuse can be applied as long as the voltage/current ratings are fitting the installation and the IR (Interrupt Rating) of the fuse is at least 15000Amps.

** Installation dependent

3.1.3 MasterBus configuration (parallel connection, total maximum current < 500 Amps)

Refer to the single battery manual for explanation of the Stop Charge event.



CAUTION!

Configuration of the Stop Charge event is mandatory to prevent major damage to the MLi Ultra batteries!

3.1.4 Commissioning (parallel connection, total maximum current < 500 Amps)

During commissioning, first the functioning of the connected cut off relay must be checked. Important is, the relay reacts correctly on a MasterBus event, in this case by operating the buttons in the MasterBus monitoring screen. Further, a wiring check is necessary. This is done by reading the current measured by the battery, in the monitoring screen. Make sure the batteries have approximately equal states of charge before connecting in parallel. Follow next steps.

- 1 UNLOCK the relay, refer to single battery manual section 4.8.
- 2 Enter on the MasterBus control panel the MasterBus MLi Ultra monitoring page. Operate the Close Relay button at the bottom of this page. If the relay is closed (On), the knob position must be shifted inwards. See figure 3-2.
- 3 Operate the Open Relay button on the last battery (figure 3-1, battery 14). If the relay is open (Off), the knob position must be outwards. Keep the relay open.
- 4 Install all fuses.
- 5 Switch On the load.
- 6 Verify on the MLi Ultra monitoring page that there is no current flow. See figure 3-3.
- 7 Close the relay with the first battery (figure 3-1, battery 11). Verify that a current is flowing *out* of the battery (negative value).
- 8 Switch Off the load, switch On the charger and verify that a current is flowing into the battery (positive value).
- 9 If necessary, check if the battery is in MasterBus Powering mode. See single battery manual section 8.1 Configuration: MasterBus Power.
- 10 If necessary, remove the MasterBus control panel from the MasterBus network.

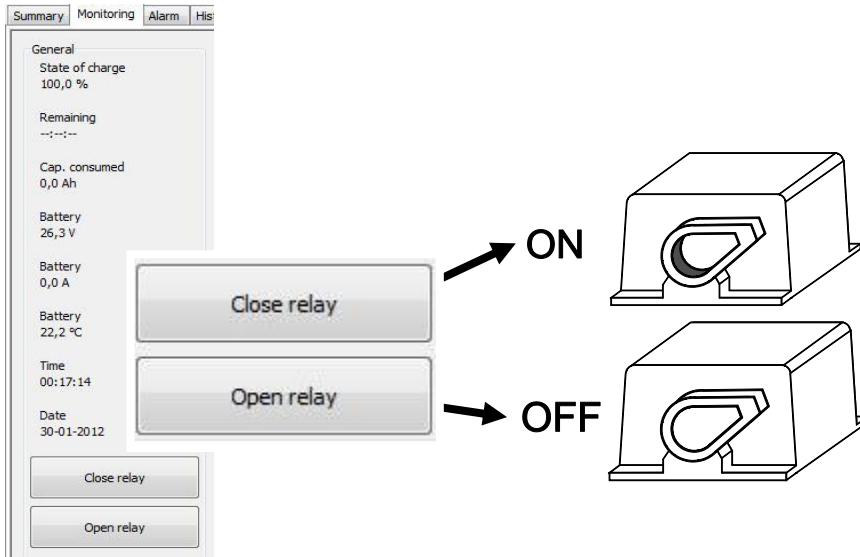

Figure 3-2: Buttons for closing and opening the relay

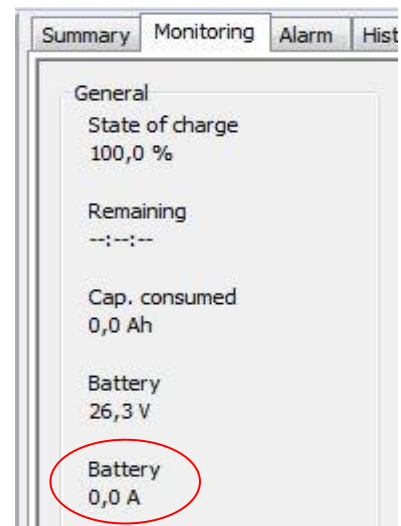

Figure 3-3: Checking zero current

3.2 PARALLEL CONNECTION, TOTAL MAXIMUM CURRENT > 500 A, MAX 500 A PER BATTERY

3.2.1 Schematic installation (parallel connection, total maximum current > 500 Amps)

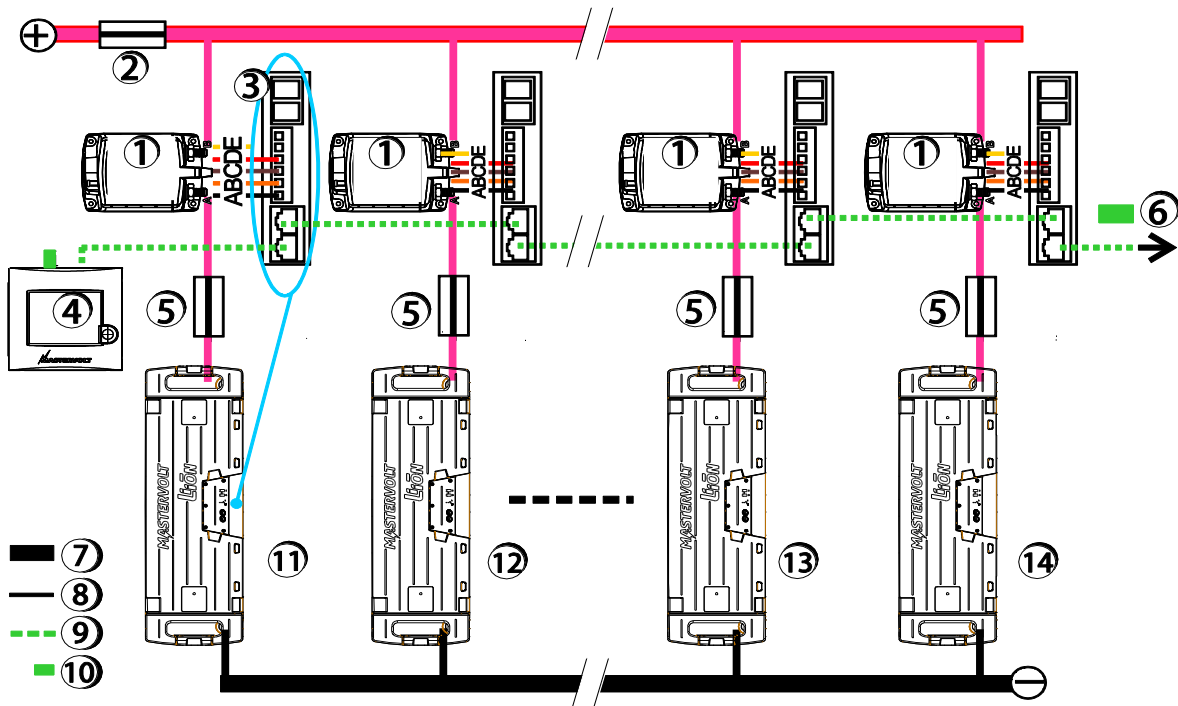

Figure 3-4: Parallel connection, current over 500A

- | | | |
|----------------------------------|------------------------------------|----------------------------|
| 1. Safety relay | 5. Fuse in positive battery line | 9. MasterBus cable |
| 2. Main fuse in positive bus bar | 6. MasterBus connection to charger | 10. MasterBus terminator |
| 3. Communication module | 7. Busbar | 11-14. MLi Ultra battery |
| 4. MasterBus display | 8. Relay cable | A- E. Refer to figure 1-2. |

Follow next steps to install the safety relay:

- 1 Move the safety relay in the LOCK OFF position. See single battery manual section 4.8.
- 2 Connect the DC main wiring as indicated but do not place the Main fuse yet.
- 3 Connect the wiring for the control circuit of the safety relay as indicated in figure 1-2.
- 4 Connect the MasterBus cabling between the devices as indicated. Follow single battery manual section 5.2.
- 5 Add a MasterBus control panel to the MasterBus network.

3.2.2 Required materials (parallel connection, total maximum current > 500 Amps)

Quantity	Mastervolt	Description
@ 12V	@ 24V	Part number
n	--	66012500 Li-ion Battery MLi Ultra 12/2500
n	--	66015000 Li-ion Battery MLi Ultra 12/5000
--	n	66025000 Li-ion Battery MLi Ultra 24/5000
n	--	79007700 Safety relay 12V/500A, part # 7700
--	n	79007702 Safety relay 24V/500A, part # 7702
n	n	77049000 500A Fuse to protect the DC Main Wiring*
n	n	778T2S600 T-Fuse holder for 77049000
1	1	MasterBus control panel (see single battery manual section 6.2)
**	**	DC Main Wiring, with Main Fuse depending on system current
**	**	Wiring for the safety relay control circuit, minimum cross section: 0.5mm ²
**	**	MasterBus communication cables

n number of MLi batteries

*Any other fuse can be applied as long as the voltage/current ratings are fitting the installation and the IR (Interrupt Rating) of the fuse is at least 15000Amps.

** Installation dependent

3.2.3 MasterBus configuration (parallel connection, total maximum current > 500 Amps)

Refer to the single battery manual for explanation of the Stop Charge event.



CAUTION!

Configuration of the Stop Charge event is mandatory to prevent major damage to the MLi Ultra batteries!

3.2.4 Commissioning (parallel connection, total maximum current > 500 Amps)

During commissioning, first the functioning of the connected cut off relay must be checked. Important is, the relay reacts correctly on a MasterBus event, in this case by operating the buttons in the MasterBus monitoring screen. Further, a wiring check is necessary. This is done by reading the current measured by the battery, in the monitoring screen. Make sure the batteries have approximately equal states of charge before connecting in parallel. Follow next steps.

- 1 UNLOCK the relay, refer to single battery manual section 4.8.
- 2 Enter on the MasterBus control panel the MasterBus MLi Ultra monitoring page. Operate the Close Relay button at the bottom of this page. If the relay is closed (On), the knob position must be shifted inwards. See figure 3-5.
- 3 Operate the Open Relay button. If the relay is open (Off), the knob position must be outwards. Keep the relay open.
- 4 Install all fuses.
- 5 Switch On the load.
- 6 Verify on the MLi Ultra monitoring page that there is no current flow. See figure 3-6.
- 7 Close the relay and verify that a current is flowing *out* of the battery (negative value).
- 8 Switch Off the load, switch On the charger and verify that a current is flowing into the battery (positive value).
- 9 If necessary, check if the battery is in MasterBus Powering mode. See single battery manual section 8.1 Configuration: MasterBus Power.
- 10 If necessary, remove the MasterBus control panel from the MasterBus network.

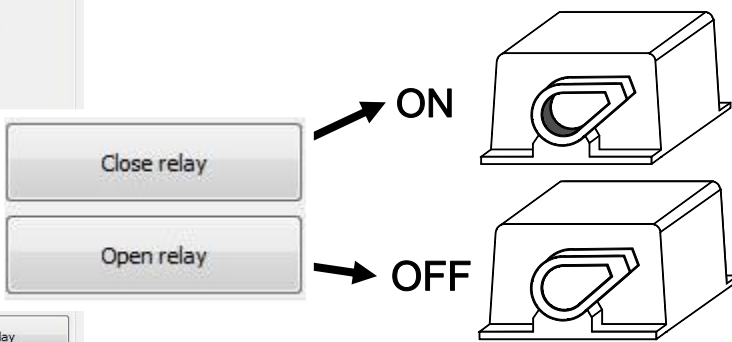

Figure 3-5: Buttons for closing and opening the relay

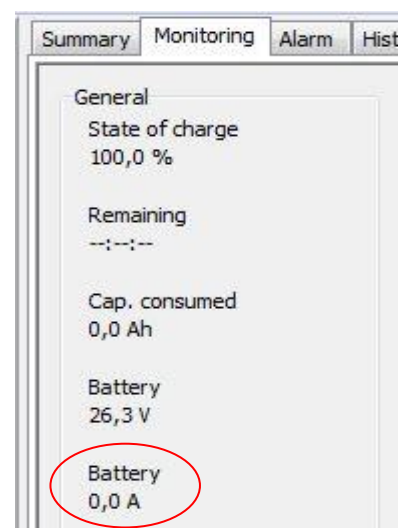
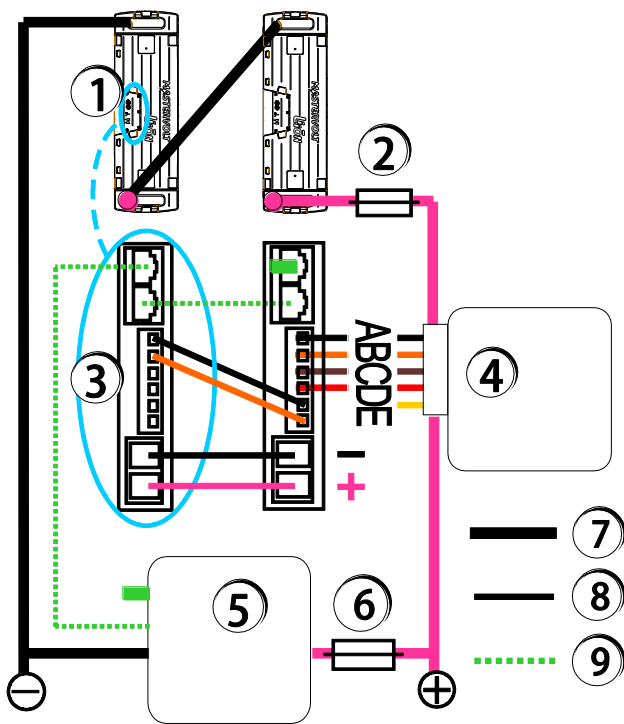

Figure 3-6: Checking zero current

3.3 SERIAL CONNECTION 48V, USING ONE CHARGER FOR TWO BATTERIES

3.3.1 Schematic installation (Serial connection 48V, one charger for two batteries)



1. MLi Ultra battery
 2. Main fuse in positive battery line
 3. Communication module
 4. 48V relay to be operated directly like shown or via the MasterBus operated Digital AC 1x6A on the relay coils. See single battery manual section 7.6.1 for an example.
 5. 48V MasterBus compatible charger
 6. Fuse to protect the charge wiring
 7. DC cable
 8. Relay wiring
 9. MasterBus cable.
- A-E Refer to figure 1-2.

Figure 3-7: Serial connection with one charger for all batteries

Follow next steps to install the safety relay:

- 1 Move the safety relay in the LOCK OFF position. See section 4.8.
- 2 Connect the DC main wiring as indicated but do not place the Main fuse yet.
- 3 Connect the wiring for the control circuit of the safety relay as indicated in figure 1-2.
- 4 Connect the MasterBus cabling between the devices as indicated. Keep the rules in mind as described in section 5.2.
- 5 Add a MasterBus control panel to the MasterBus network.

3.3.2 Required materials (Serial connection 48V, one charger for two batteries)

Quantity		Mastervolt	Description
@ 12V	@ 24V	Part number	
n	--	66012500	Li-ion Battery MLi Ultra 12/2500
1	--	66015000	Li-ion Battery MLi Ultra 12/5000
--	1	66025000	Li-ion Battery MLi Ultra 24/5000
1	1	77031500	Digital AC 1x6A
1	--	79007700	Safety relay 12V/500A, part # 7700
--	1	79007702	Safety relay 24V/500A, part # 7702
1	1	77049000	500A Fuse to protect the DC Main Wiring*
1	1	778T2S600	T-Fuse holder for 77049000
1	1		MasterBus control panel (see single battery manual section 6.2)
**	**		DC Main Wiring, with Main Fuse depending on system current
**	**		Wiring for the safety relay control circuit, minimum cross section: 0.5mm ²
**	**		MasterBus communication cables

*Any other fuse can be applied as long as the voltage/current ratings are fitting the installation and the IR (Interrupt Rating) of the fuse is at least 15000Amps.

** Installation dependent

3.3.3 MasterBus configuration (Serial connection 48V, one charger for two batteries)

Refer to the single battery manual for explanation of the Stop Charge event.



CAUTION!

Configuration of the Stop Charge event is mandatory to prevent major damage to the MLI Ultra batteries! Make sure this event is configured for every MLI battery in your system!

3.3.4 Commissioning (Serial connection 48V, one charger for two batteries)

During commissioning, first the functioning of the connected cut off relay must be checked. Important is, the relay reacts correctly on a MasterBus event, in this case by operating the buttons in the MasterBus monitoring screen. Further, a wiring check is necessary. This is done by reading the current measured by the battery, in the monitoring screen. Make sure the batteries have approximately equal states of charge before connecting in parallel. Follow next steps.

- 1 UNLOCK the relay, refer to section 4.8.
- 2 Enter on the MasterBus control panel the MasterBus MLI Ultra monitoring page. Operate the Close Relay button at the bottom of this page. If the relay is closed (On), the knob position must be shifted inwards. See figure 3-8.
- 3 Operate the Open Relay button. If the relay is open (Off), the knob position must be outwards. Keep the relay open.
- 4 Install all fuses.
- 5 Switch On the load.
- 6 Verify on the MLI Ultra monitoring page that there is no current flow. See figure 3-9.
- 7 Close the relay and verify that a current is flowing *out* of the battery (negative value).
- 8 Switch Off the load, switch On the charger and verify that a current is flowing into the battery (positive value).
- 9 If necessary, check if the battery is in MasterBus Powering mode. See single battery manual section 8.1 Configuration: MasterBus Power.
- 10 If necessary, remove the MasterBus control panel from the MasterBus network.

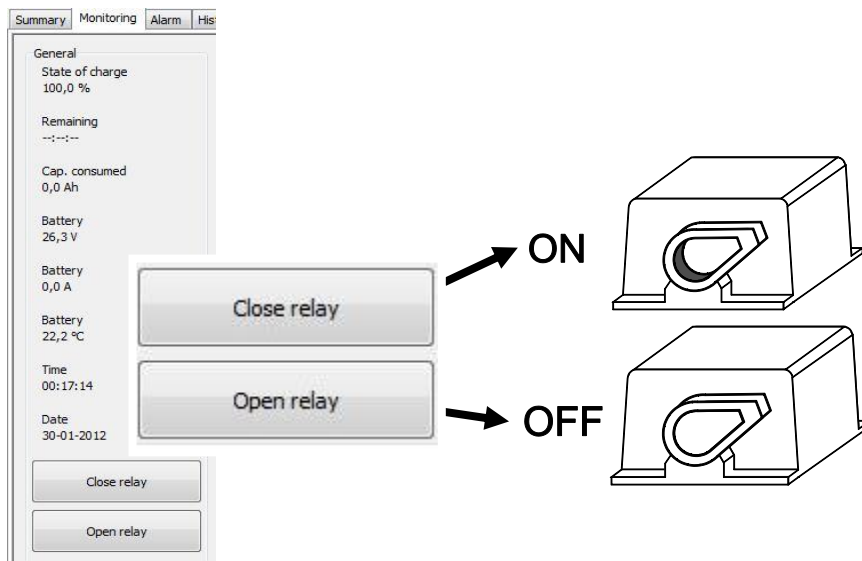

Figure 3-8: Buttons for closing and opening the relay

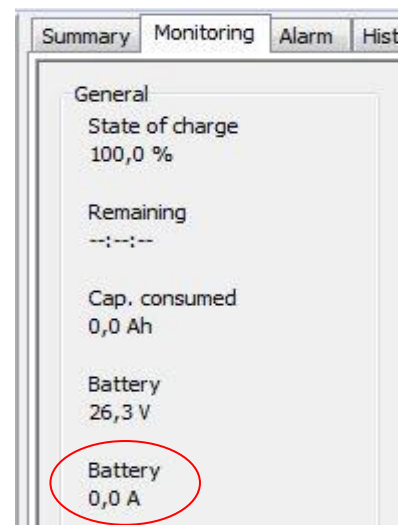

Figure 3-9: Checking zero current

3.4 SERIAL CONNECTION MAXIMUM 10 BATTERIES

3.4.1 Schematic installation (Serial connection, maximum 10 batteries)

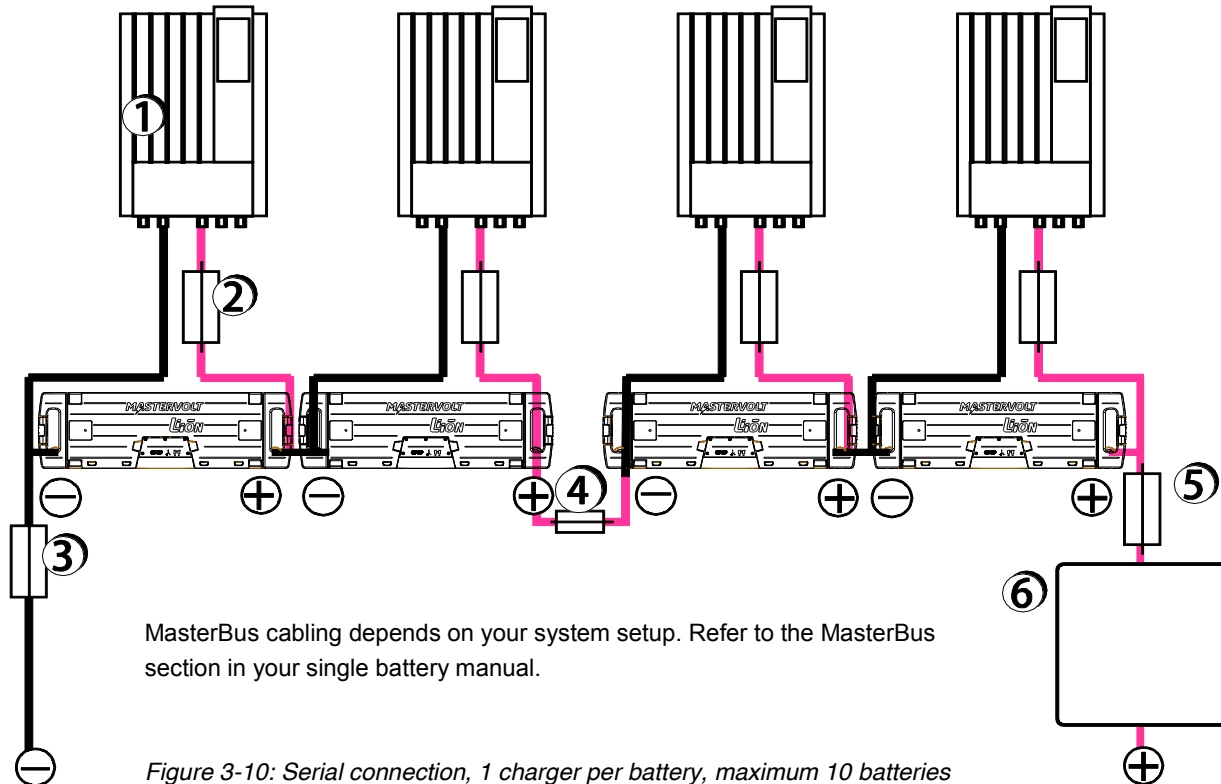

Figure 3-10: Serial connection, 1 charger per battery, maximum 10 batteries

- | | | |
|----------------------------------|---------------------------------|--|
| 1. MasterBus compatible charger | 4. Fuse for every two batteries | 6. Safety relay suitable for the voltage |
| 2. Fuse in positive charger line | 5. Fuse in positive DC line | |
| 3. Fuse in minus DC line | | |

Follow next steps to install the safety relay:

- 1 Move the safety relay in the LOCK OFF position. See single battery manual section 4.8.
- 2 Connect the DC main wiring as indicated but do not place the Main fuse yet.
- 3 Connect the wiring for the control circuit of the safety relay as indicated.
- 4 Connect the MasterBus cabling between the devices as indicated. Keep the rules in mind as described in single battery manual section 5.2.
- 5 Add a MasterBus control panel to the MasterBus network.

3.4.2 Required materials (Serial connection, maximum 10 batteries)

Quantity		Mastervolt Part number	Description
@ 12V	@ 24V		
n	--	66012500	Li-ion Battery MLi Ultra 12/2500
n	--	66015000	Li-ion Battery MLi Ultra 12/5000
--	n	66025000	Li-ion Battery MLi Ultra 24/5000
n	n	**	Mass Charger
1	1		500A Fuse to protect the DC Main Wiring *
1	1		MasterBus control panel (see single battery manual section 6.2)
**	**		High voltage safety relay
**	**		DC Main Wiring, with Main Fuse depending on system current
**	**		Wiring for the safety relay control circuit, minimum cross section: 0.5mm ²
**	**		MasterBus communication cables

n number of MLi batteries

* The voltage/current ratings must fit the installation and the IR (Interrupt Rating) of the fuse must be at least 15000Amps.

** Installation dependent

3.4.3 MasterBus configuration (Serial connection, maximum 10 batteries)

Refer to the single battery manual for explanation of the Stop Charge event.



CAUTION!

Configuration of the Stop Charge event is mandatory to prevent major damage to the MLI Ultra batteries!

3.4.4 Commissioning (Serial connection, maximum 10 batteries)

During commissioning, first the functioning of the connected cut off relay must be checked. Important is, the relay reacts correctly on a MasterBus event, in this case by operating the buttons in the MasterBus monitoring screen. Further, a wiring check is necessary. This is done by reading the current measured by the battery, in the monitoring screen.



CAUTION!

To prevent a high compensation current, make sure the batteries have approximately equal states of charge before connecting in parallel!

Follow next steps.

- 1 UNLOCK the relay, refer to section 4.8.
- 2 Enter on the MasterBus control panel the MasterBus MLI Ultra monitoring page. Operate the Close Relay button at the bottom of this page. If the relay is closed (On), the knob position must be shifted inwards. See figure 3-11.
- 3 Operate the Open Relay button. If the relay is open (Off), the knob position must be outwards. Keep the relay open.
- 4 Install all fuses.
- 5 Switch On the load.
- 6 Verify on the MLI Ultra monitoring page that there is no current flow. See figure 3-12.
- 7 Close the relay and verify that a current is flowing *out* of the battery (negative value).
- 8 Switch Off the load, switch On the charger and verify that a current is flowing into the battery (positive value).
- 9 If necessary, check if the battery is in MasterBus Powering mode. See single battery manual section 8.1 Configuration: MasterBus Power.
- 10 If necessary, remove the MasterBus control panel from the MasterBus network.
Continue with chapter 8.

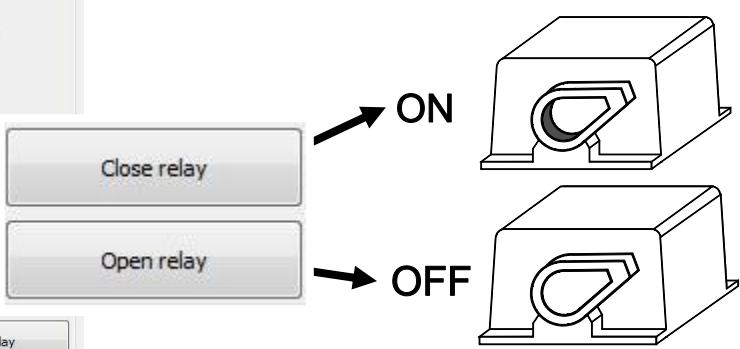
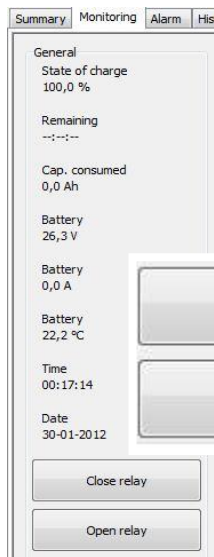

Figure 3-11: Buttons for closing and opening the relay

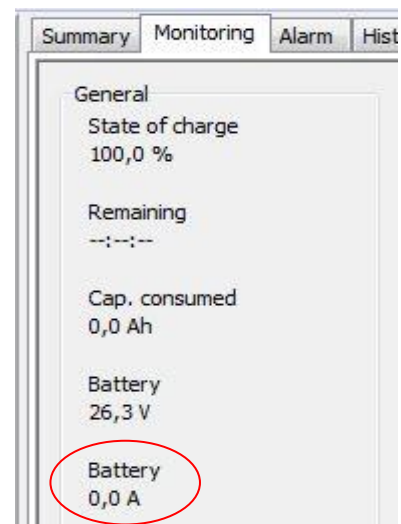

Figure 3-12: Checking zero

4 ORDERING INFORMATION

Part number	Description
66012500	Li-ion Battery MLi Ultra 12/2500
66015000	Li-ion Battery MLi Ultra 12/5000
66025000	Li-ion Battery MLi Ultra 24/5000
79007700	Safety relay 12V/500A, part # 7700
79007702	Safety relay 24V/500A, part # 7702
77031500	Digital AC 1x6A
77049000	500A Fuse to protect the DC Main Wiring*
778T2S600	T-Fuse holder for 77049000
77030450	MasterBus – Serial Interface
77010305	MasterView Easy MkII
77010400	MasterView System panel
77030100	MasterBus USB interface, required as interface between your PC and the MasterBus network
77040000	MasterBus terminator for the MasterBus network
77040100	MasterBus connection cable 1,0m / 3.3ft
77040300	MasterBus connection cable 3,0m / 10ft
77050000	Complete set to assemble MasterBus cables. Delivery includes: 100m / 330ft MasterBus cable, 50 pcs. modular jacks and crimping tool

5 TECHNICAL INFORMATION MULTIPLE BATTERIES

5.1 SPECIFICATIONS

Model	MLi Ultra 12/2500	MLi Ultra 12/5000	MLi Ultra 24/5000
Article number	66012500	66015000	66025000
Maximum number of batteries in parallel	No maximum	No maximum	No maximum
Maximum number of batteries in series			
Using the balance line	2	2	2
Using one charger per battery	10	10	10



Snijdersbergweg 93, 1105 AN Amsterdam, The Netherlands

Tel : + 31-20-3422100

Fax : + 31-20-6971006

Email : info@mastervolt.com

www.mastervolt.com