



Black

White

CO29

FEATURES

PERFORMANCE

- 2.1 cubic feet overall refrigerator capacity maximizes storage of food and beverage items
- High output daily ice rate of up to 18 lbs and storage of up to 13 lbs of crescent ice (1/2" W x 3/4" H x 2-1/2" L)
- Temperature setting from 34 to 45° F provides flexibility for preserving a wide variety of items
- No drain required makes it easy and inexpensive to install and requires only a 1/4" outside diameter water line
- Conserves energy by using less electricity than a 75-watt light bulb
- Uses under 3 gallons of water to produce 25 lbs of ice
- Mechanical controlled passive cooling system
- Manual defrost maximizes ice making potential
- 220 volt model available with a 4 – 6 week order lead time

INTERIOR / EXTERIOR

- Vinyl coated cabinet helps withstand tough marine environments
- Corrosion and UV resistant marine grade hardware provide better product longevity in harsh environments
- Aluminum framed door with anodized durable aluminum handle weathers outdoor elements on white model

INTEGRATION

- Field reversible door with zero clearance door swing simplifies installation
- Black model will accept a 1/4" insert panel
- No additional clearance around sides, top or rear of unit is needed for ventilation
- Sleek and contemporary look provides a very clean, high-end aesthetic
- Do not obstruct front grille air flow
- For proper installation and cut-out dimensions, see backside for details

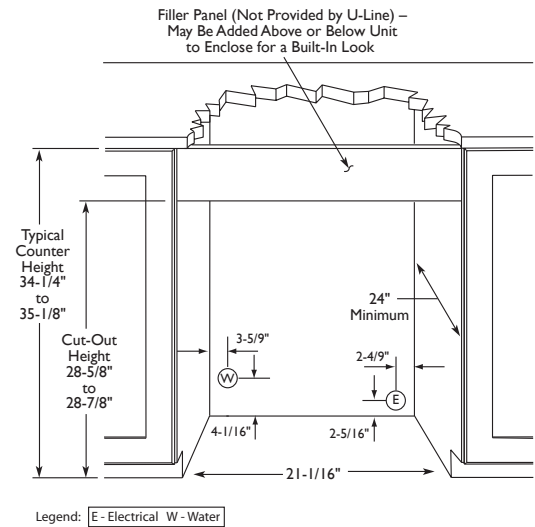
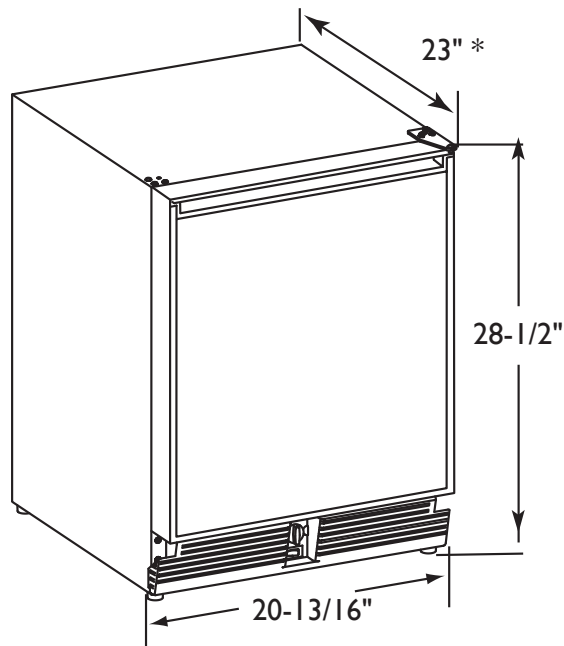

CO29B Black Model

* Add 15/16" to depth for water line clearance

DIMENSIONS AND SPECIFICATIONS

OVERALL DIMENSIONS

| | |
|---------------------------------------|---------------------|
| Height | 28-1/2" (72.4) |
| Width | 20-13/16" (52.9) |
| Depth | 23" (58.4) |
| Shipping weight: | 98 lbs (44 kg) |
| Running amps | 2.5 |
| Maximum start-up amps | 18.0 |
| Amps pertain to voltage rating | 110/115 volt, 60 Hz |
| Optional in 220/230 voltage, 50/60 Hz | |

Capacities:

| | |
|----------------------------------|----------------|
| Defrost technology | Manual defrost |
| Refrigerator volume | 2.1 Cu. Ft |
| Approximate daily ice production | Up to 18 lbs |
| Ice Storage | Up to 13 lbs |

*When installing a left-hand hinge model, allow a 145° door swing for proper removal of ice bin

CO29

| | |
|------------|---------------|
| Black 110V | U-CO29B-03 |
| Black 220V | U-CO29BTP-20 |
| White 110V | U-CO29WH-03 |
| White 220V | U-CO29WHTP-20 |

Please visit www.u-line.com for installation guide.

All specifications are subject to change without notice.

