



White

## WH95TP

### FEATURES

#### PERFORMANCE

- High output daily ice rate of up to 23 lbs and storage of up to 12 lbs of crescent ice (1/2" W x 3/4" H x 2-1/2" L)
- Conserves energy by using less electricity than a 75-watt light bulb
- Uses under 3 gallons of water to produce 25 lbs of ice
- No drain required makes it easy and inexpensive to install and requires only a 1/4" outside diameter water line
- Manual defrost maximizes ice making potential
- 220 volt model available with a 4 – 6 week order lead time

#### INTERIOR / EXTERIOR

- Vinyl coated cabinet helps withstand tough marine environments
- Corrosion and UV resistant marine grade hardware provide better product longevity in harsh environments
- Aluminum framed door with durable aluminum handle weathers outdoor elements
- Travel pin included for optimized, hygienic and safe at-sea travel and storage

#### INTEGRATION

- Field reversible door with zero clearance door swing simplifies installation
- 1/2" flange flush to cabinet
- No additional clearance around sides, top or rear of unit is needed for ventilation
- Sleek and contemporary look provides a very clean, high-end aesthetic
- Do not obstruct front grille air flow
- For proper installation and cut-out dimensions, see backside for details

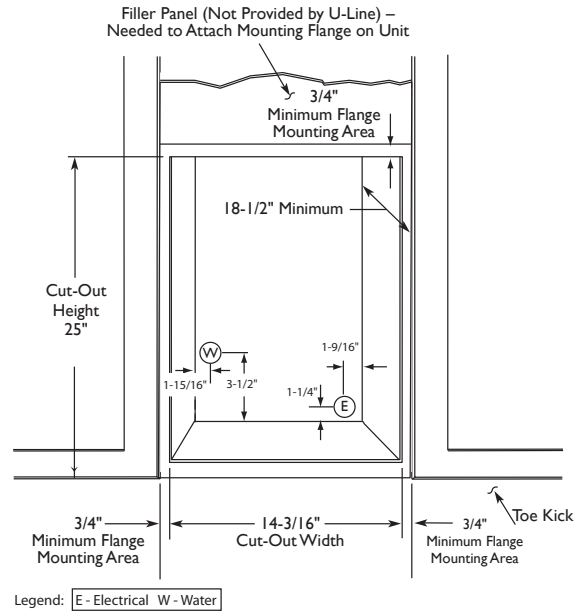
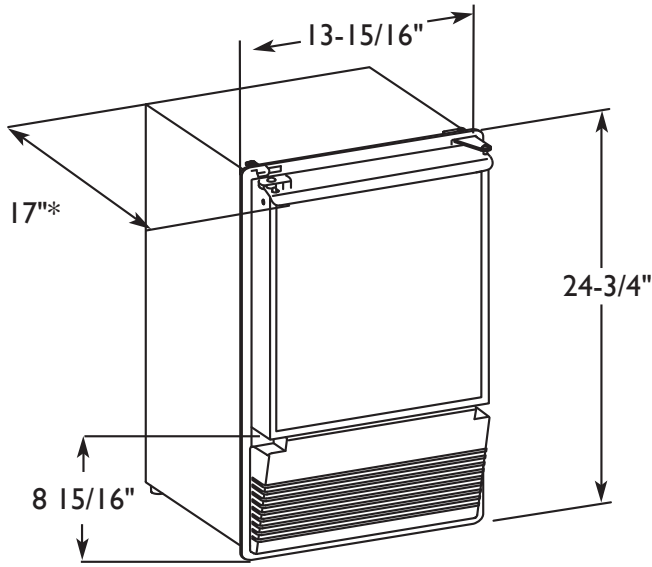

**WH95TP White Model**

\* Add 1-1/2" for water line clearance

**DIMENSIONS AND SPECIFICATIONS**

**OVERALL DIMENSIONS**

Height	24-3/4" (62.8)
Width	13-15/16" (37.8)
Depth	17" (43.2)

**Shipping weight:**

Black and white models	66 lbs (30 kg)
------------------------	----------------

Running amps	2.5
Maximum start-up amps	18.0
Amps pertain to voltage rating	110/115 volt, 60 Hz
Approximate daily ice production	Up to 23 lbs
Ice storage	Up to 12 lbs

Optional in 220/230 voltage, 50/60 Hz  
 On the 220/230 volt models, amps are decreased by approximately 50 percent.

WH95TP	
White 110V	ULN-WH95TP-03
White 220V	ULN-WH95TP-20

Please visit [www.u-line.com](http://www.u-line.com) for installation guide.

All specifications are subject to change without notice.

