

# VacuFlush® Vacuum Components

## The Heart of VacuFlush® Power



J series vacuum generator

S series low-profile vacuum generator

### J Series Vacuum Generator (model VG4)

As the most versatile, efficient and quiet vacuum sources developed by Dometic, J series vacuum generators offer boatbuilders more reasons than ever to install premium VacuFlush toilet systems. Along with the most efficient water and power consumption, they operate much more quietly than macerator toilet motors, and can be configured to most any marine plumbing application.

#### Key Benefits

- Adjustable components accommodate diverse layouts
- Large 2 in./51 mm ID openings improve flow
- Precise tolerances of injection-molded tank optimize efficiency and reliability
- Pre-wired and assembled

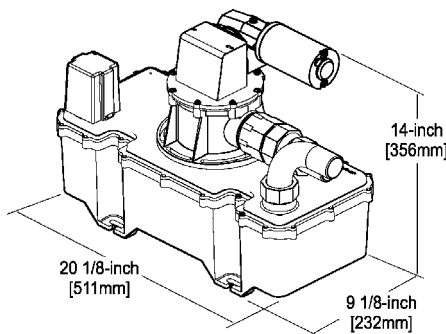

### S Series Low-profile Vacuum Generator (model LPVG)

Where space is limited, this low-profile unit is the perfect fit. Provided as a single unit, the whisper-quiet pump and sturdy polyethylene tank can also be installed separately for unique applications.

#### Key Benefits

- Creates powerful vacuum for all VacuFlush toilets
- Vacuum pump and tank can be plumbed up to 3 feet (0.9 m) apart if necessary (requires additional sanitation hose)
- Pre-wired and assembled

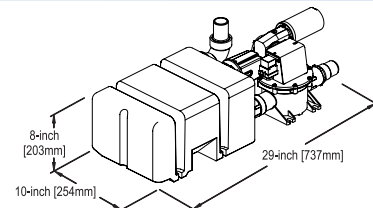

### J and S Series Vacuum Generator Requirements

ELECTRICAL	Power draw (avg.)	6 amps @ 12 V DC; 3 amps @ 24 V DC
	Circuit breaker/fuse*	10 amps @ 12 V DC; 5 amps @ 24 V DC
INLET PLUMBING	ID	1.5 in./38 mm sanitation hose or PVC pipe
	Horizontal run	50 ft./15.2 m max. from toilet discharge
	Vertical run	6 ft./1.8 m max. from toilet discharge
DISCHARGE PLUMBING	ID	1.5 in./38 mm sanitation hose or PVC pipe
	Horizontal run	20 ft./6.1 m max. to holding tank
	Vertical run	6 ft./1.8 m max. to holding tank
REQUIRED COMPONENT	VacuFlush toilet †	

\* Requires separate circuit breaker or fuse from other electrical equipment.

† Purchased separately. Electronic-flush VacuFlush toilets require separate electrical circuit. Refer to toilet specifications. Specifications subject to change without notice.

## M Series Vacuum Pump (model M)

Install up to eight VacuFlush toilet/vacuum tank combinations to ONE super-powerful M series vacuum pump. It's ideal for multi-head superyachts and heavy-use charters or rentals.

### Key Benefits

- Heavy-duty bronze body
- Runs dry without damage
- Passes objects up to 1 in. (25 mm) diameter
- 1/2-HP motor, standard (3/4-HP motor, optional)



M series vacuum pump

## M Series Vacuum Pump Requirements

ELECTRICAL	Power draw (avg.)	40 amps @ 12 V DC; 20 amps @ 24 V DC; 8 amps @ 115 V AC
	Circuit breaker/fuse*	50 amps @ 12 V DC; 25 amps @ 24 V DC; 10 amps @ 115 V AC
INLET PLUMBING	ID	1.5 in./38 mm sanitation hose or PVC pipe
	Horizontal run**	unspecified
DISCHARGE PLUMBING	ID	1.5 in./38 mm sanitation hose or PVC pipe
	Horizontal run	20 ft./6.1 m max. to holding tank
	Vertical run	6 ft./1.8 m max. to holding tank
REQUIRED COMPONENTS	Vacuum tank, VacuFlush toilet †	

\* Requires separate circuit breaker or fuse from other electrical equipment.

\*\* Recommend run to be parallel to or lower than vacuum tank discharge outlet.

† Purchased separately.

Specifications subject to change without notice.

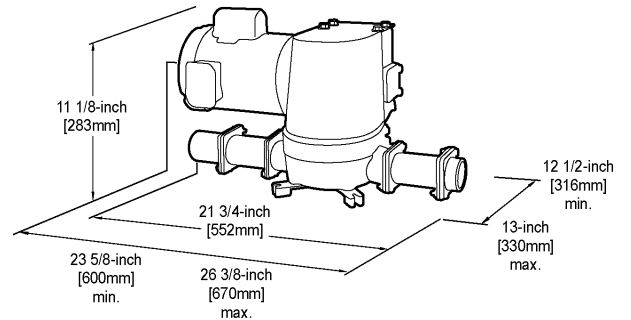

## S Series Vacuum Pump (model S)

Proven in thousands of motor yachts, our bellows-style vacuum pump has been powering VacuFlush toilets for over 30 years. Connects to separate vacuum tank (model VT).

## S Series Vacuum Pump Requirements

ELECTRICAL	Power draw (avg.)	6 amps @ 12 V DC; 3 amps @ 24 V DC
	Circuit breaker/fuse*	10 amps @ 12 V DC; 5 amps @ 24 V DC
INLET PLUMBING	ID	1.5 in./38 mm sanitation hose or PVC pipe
	Horizontal run**	3 ft./0.9 m max. from vacuum tank
DISCHARGE PLUMBING	ID	1.5 in./38 mm sanitation hose or PVC pipe
	Horizontal run	20 ft./6.1 m max. to holding tank
	Vertical run	6 ft./1.8 m max. to holding tank
REQUIRED COMPONENTS	Vacuum tank, VacuFlush toilet †	

\* Requires separate circuit breaker or fuse from other electrical equipment.

\*\* Must be parallel to or lower than vacuum tank discharge outlet.

† Purchased separately.

Specifications subject to change without notice.

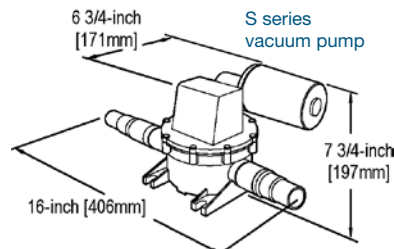

S series vacuum pump

Vacuum tank

## Vacuum Tank (model VT)

This tank stores a vacuum force to instantly clear a VacuFlush toilet bowl with every flush. Connecting between a VacuFlush toilet and S or M series vacuum pump, it installs horizontally, vertically or suspended to accommodate special applications.

